

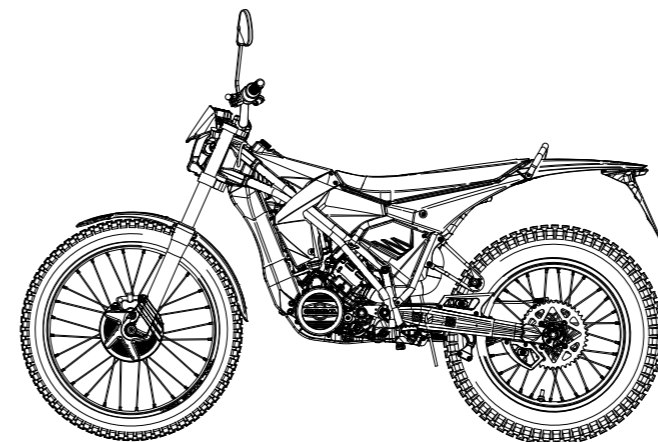

USER MANUAL EXPLORER



We at OSSA Motor would like to thank you for purchasing one of our products.

When designing the Explorer, OSSA engineers and designers were based on the following approach: create a bike that was easier to reach the most difficult places. Its extreme lightness and trials qualities, combined with its enhanced ergonomics, make it possible to enjoy both tours real quiet as trial areas.

OSSA motorcycles have been designed, assembled and tested by experts, and each of its parts has been produced under the supervision of OSSA engineers so as to obtain the best possible results and the best possible performance.

At OSSA Motor we know that each motorcycle model is unique and has its own features, which is why we dedicate so much time on research and design for each item.

Read this manual thoroughly and keep it in a safe place. This manual provides technical information necessary for keeping your new Explorer motorcycle in full working condition. It provides information on common aspects for the motorcycle's upkeep and fine tuning. In the event of questions or queries on aspects not mentioned in this manual, you should consult the OSSA official distributor or a specialist engineer.

Follow each stage of the instructions provided below for obtaining good results.

These instructions are accompanied by icons to make reading quicker and easier.



ATTENTION – This symbol indicates that special attention must be paid!



INFORMATION – Informative note, advice.

Some of the indications specified in this manual are to prevent possible harm from being inflicted on people or material. Not following the instructions may result in serious consequences, which could put people's lives at risk.

This manual has been put together with the OSSA Explorer current layout. However, OSSA Motor reserves the right to make changes to this layout without prior notification to consumers. In the event of this taking place, your dealer will provide you with the relevant information.



- Never overload the motorcycle.
- Any additional weight could destabilise the motorcycle which may cause accidents that incur serious injury or even death.

Both your safety and the safety of others are very important when riding a motorcycle.

Some important advice for using your motorcycle correctly is detailed below.

- Always ride in a responsible way.

- Always use a helmet.

- This motorcycle is designed to be used in both urban and rural areas. It should be used, however, while respecting other people and the environment. If, in your geographical area, the use of motorcycles in rural areas is restricted, you must respect the law.

- Always wear appropriate clothing and protective accessories. Gloves, boots and thick trousers, among others, are recommended. Do not wear baggy clothing that might get caught on a mechanism in the motorcycle.

- Be careful with the exhaust system! The exhaust system gets extremely hot during and after use of the motorcycle. In the event of suffering burns, see a doctor as soon as possible.

- Take the time necessary to become familiar with your new motorcycle.

- Make sure your motorcycle is serviced regularly to avoid breakdowns while driving.

- Never ride if you have consumed alcohol or any type of substance (medication, drugs) that might affect your driving capability.

- Moderate speed. Do not exceed 63 KPH (40 MPH).

- Do not cross water areas.

- Do not release your hands from the handlebars.

- Do not perform risky maneuvers and stunts.

- Do not use your motorcycle for transporting or towing loads. In the event of needing to carry loads, always use the box under the seat. This load may be light-weight and small in volume so that driving is not affected. Ensure that there are no loose leashes or other elements that might get caught inside a mechanism. Never apply additional weight to the handlebars, fork or mudguards. Be specially careful when transporting any type of load.

- Do not clean the motorcycle with pressurized-water equipment, since this may damage the parts.



Introduction	3
Important warning	4
Safety	5
Contents	7
Technical specifications	8-9
Recommendations	10
Section 1 - Components	11
Location	12-14
Multi-function box	15-22
Control pad	23
Suspensions	24
Seat	25
Anti-theft immobilizer	26
Start lever	27
Fuel tank	28-30
Section 2 – Maintenance and basic operations	31
Maintenance grid	32-33
Adjustments to the motorcycle controls	34
Electric connections	35
Simplified lighting wiring diagram	36
Simplified injection wiring diagram	37
Air filter	38
Radiator	39
Spark plug	40
Chain	
Tension adjustments	41
Lubrication of moving parts	42-44

Tyres	
Pressure and condition	45
Control of crankcase oil	
Filling up and draining	46
Brakes	47
Tightening torques	48
Storage	49
Troubleshooting	50-54
Registration, series number and key	56-60
Warranty conditions	61-68
Final considerations	69



ENGINE

Cylinder size	247,7 cc (Explorer 250) / 272,2 cc (Explorer 280)
Type	2 stroke inverted monocylinder with reed box admission
Cooling	Liquid cooled
Bore x Stroke	72,5x60 mm (Explorer 250) / 76x60 mm (Explorer 280)
Injection	EFI Kokusan Indirect injection
Ignition	Digital flywheel CDI Kokusan
Clutch	Hydraulic
Start	Battery-assisted kickstart

TRANSMISSION

Gearbox	6 speeds
Transmission	Primary transmission by gears, final transmission by chain.
Lubrication	Mixture 100% synthetic oil lubrication 0.9%
Gearbox and clutch lubrication	450 cc. of Gear Extreme type 75 W oil.

FRAME

Type	Made of CR-MO steel tube, with fuel tank and lower part made of forged aluminium
Front suspension	Ollé Hydraulic fork, 40 mm diameter adjustable in rebound and compression
Rear suspension	Variable progressive system with Ollé mono shock absorber with adjustable spring preload
Front brake	185 mm diameter disc with 4-piston brake caliper
Rear brake	180 mm diameter disc with 4-piston brake caliper
Front wheel	2.75x21 wheel
Rear wheel	4.00 x 18 wheel
Engine protector	Constructed in AA7075 T6
Kick-start pedal	Forged aluminium
Shift pedal	Forged aluminium with retractable toe cap



WEIGHTS AND MEASUREMENTS

Wheelbase	1.328 mm
Seat height	840 mm
Ground clearance	340 mm
Fuel tank capacity	7,6 litres (2,6 + 5 l.)
Dry weight	74 Kg

It is extremely important to follow the recommendations below in order to keep your motorcycle in full working order.

- 12 hours of running-in is recommended to ensure that the engine works correctly and for a long-lasting time period.
- It is important to run the engine for some minutes until it reaches the correct temperature to work correctly.
- The engine lubrication is a mixture of petrol-oil with a 0.9% oil proportion. Always use synthetic oil.
- When the motorcycle is new the oil must be changed for the first time after 5 hours of use and for the second time after 12 hours of use.

Section 1 - Components

- 1 Front mudguard
- 2 OSSA multi-function box
- 3 Fan and radiator
- 4 Cylinder
- 5 Sparkplug
- 6 Chain guide
- 7 Front tyre
- 8 Front fork bottles
- 9 Front fork stanchions
- 10 Shift pedal
- 11 Chain
- 12 Chain slider
- 13 Rear sprocket protector
- 14 Rear tyre

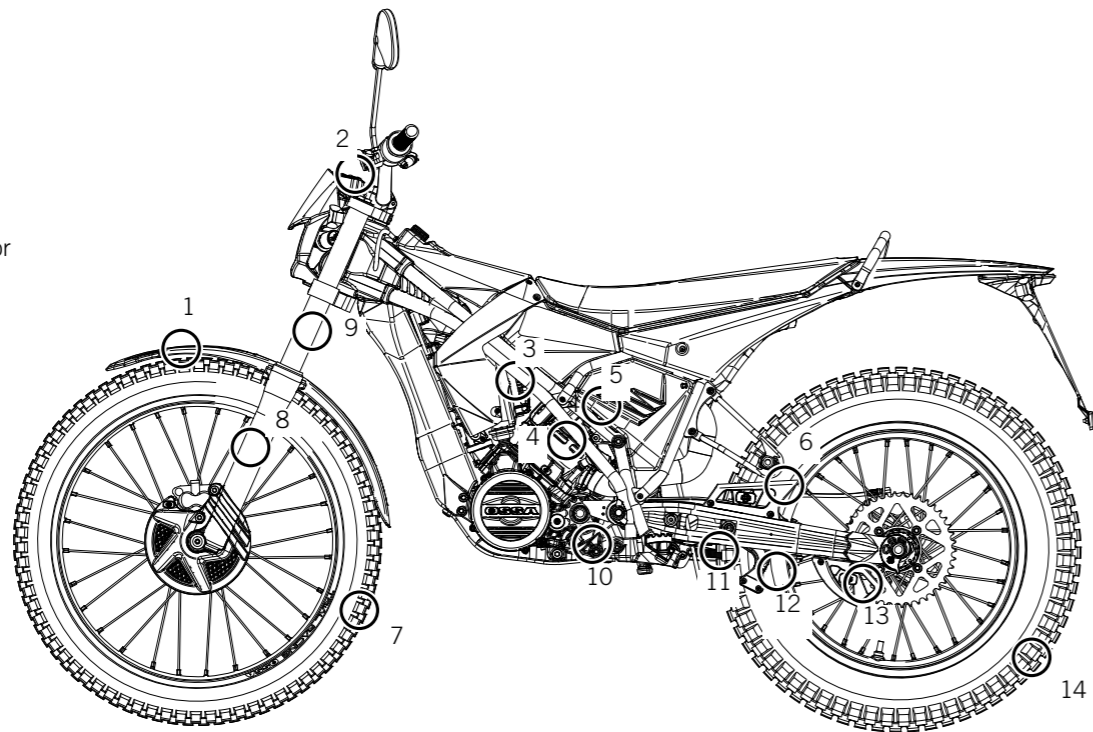

- 15 Rear brake caliper and anti-theft immobilizer
- 16 Exhaust
- 17 Kick-start pedal
- 18 Fuel tank
- 19 Rear brake disc
- 20 Swing arm
- 21 Rear brake lever
- 22 Crankcase protector
- 23 Front brake caliper
- 24 Front brake disc
- 25 Air filter
- 26 Rear footrests (depending on version)
- 27 Passenger handle

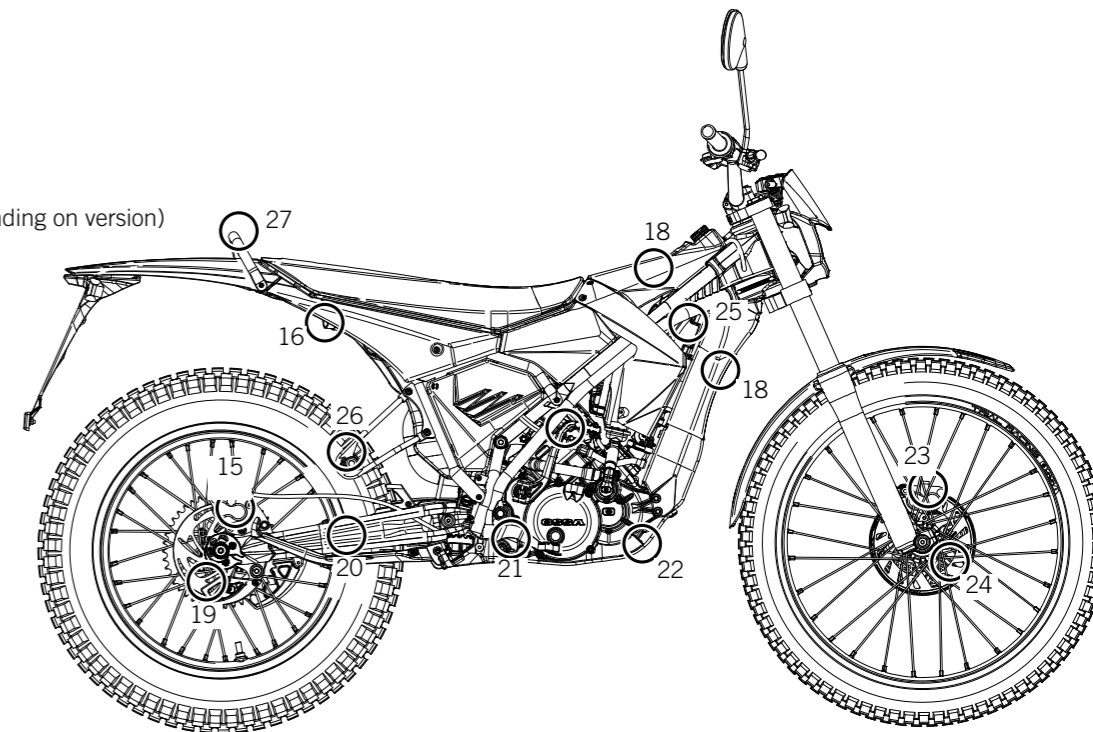

- 28 Front brake handle
- 29 Throttle grip
- 30 Throttle mechanism
- 31 Front brake pump
- 32 Clutch pump
- 33 Lights control pad
- 34 Clutch lever
- 35 Headlights
- 36 Key switch

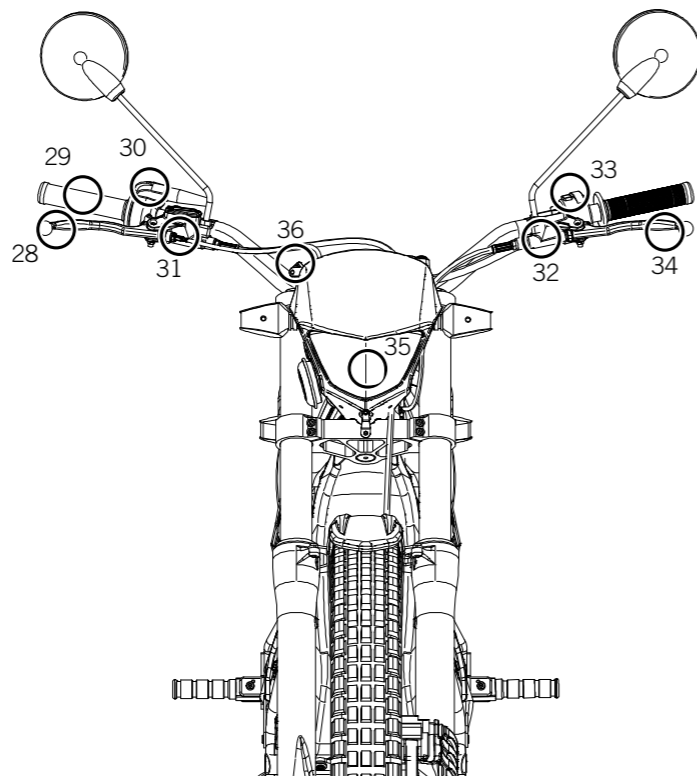

The OSSA TR multi-function box and the indicator lights next to it provide very useful information at all times. The multi-function box is a power box system with an LCD screen controlled by a console with indicator lights, located in the centre of the handle-bars.

The information displayed on the multi-function box includes: the number of revolutions made by the engine, speed, distance covered, total distance covered, time, average speed, maximum speed, environmental temperature, running time and uptime.

This device has an internal memory unit that stores data like total Km and total running time, even when it is switched off.

Some features may be personalised: the device can measure in kilometres or miles. The wheel circumference value can also be changed.

A temperature sensor warns us with a yellow light (1) when the engine temperature is excessive.

Another sensor provides a warning with a red light (2) when the rate at which the engine turns is excessive.

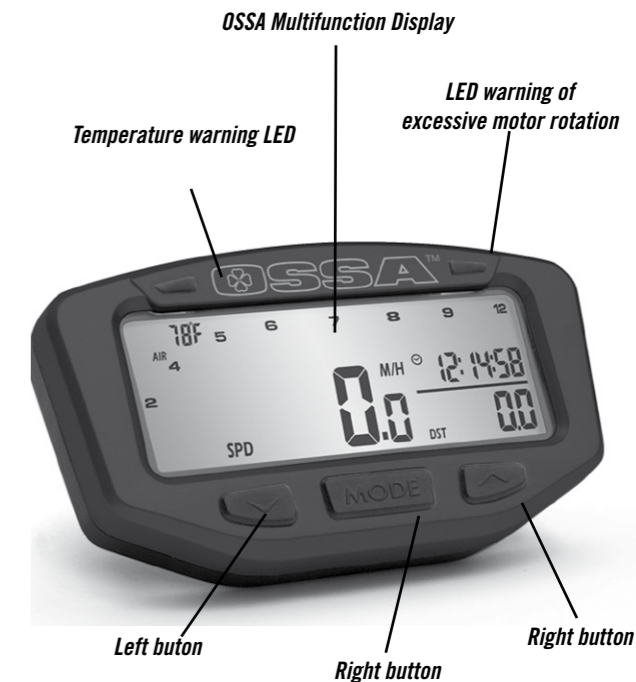

Technical features

Functions	Symbol	Technical features	Increase	Accuracy
Current speed	SDPO	4 - 399,9 Km/h o M/h	,1 Km/h o M/h+	/- 0,1%
Tachometer	RPM	0 - 19999 rpm	10 rpm+	/- 0,1%
Tachometer bar	-	0 - 12000 rpm	Variable+	/- 0,1%
Maximum speed	MS	4 - 399,9 Km/h o M/h	0,1 Km/h o M/h+	/- 0,1%
Distance covered	DST	0,0 - 19999 Km / M	0,1 Km/h o M/h+	/- 0,1%
Running time	TT	0 - 9999 hours 59 minutes	1 second	+/- 0,1%
Mileage	ODO	0,0 - 999999	1 Km	+/- 0,1%
Uptime	RT	0 - 999 hours 59 minutes	1 minute	+/- 0,1%
Accumulated uptime	ART	0 - 9999 hours 59 minutes	1 minute	+/- 0,1%
Clock	00:00:00	12:59:59 - 23:59:59	Each use	+/- 0,1%
Battery low	LO	1 year's duration approx	Each use	+/- 0,1%
Tyre size	-	0 - 3999 mm	--	

Input voltage: 9-400 V CA/CC.

Speed sensor: magnetic non-contact sensor

Tachometer input: electrical pulse sensor

Wheel circumference adjuster: 1 mm -3.999 mm (increases of 1 mm)

Running temperature / storage: from 0°C to 60°C (from 32°F to 140°F) / from -20°C to 80°C (from - 4°F to 176°F)

Battery / Life: 3V CR2032 / 1 year approx

Functions

RPM: Bar

Bar graph tachometer. The tachometer bar graph displays up to 12,000 rpm.

RPM: Digital tachometer

The RPM appear on the right side, on the second line. The digital tachometer displays up to 12,000 rpm. The tachometer signal can be captured from the sparkplug wire.

Warning of gear change due to rpm.

The rpm appear on the right side, on the second line. The digital tachometer displays up to 12,000 rpm. The tachometer signal is received from the sparkplug wire.

SPD: Speedometer

The speedometer information appears on the centre of the screen. It displays up to 399.9 km/hour or miles/hour.

MS: Maximum speed meter

It displays the maximum speed reached during the last operation after having set the counter at zero.

DST: Distance covered

It appears on the right side, on the second line of the screen. The TRIP function records the mileage accumulated by the vehicle since the last RESET.

ODO: Mileage counter

It records the distance or total accumulated mileage for the vehicle. The data is stored in the memory, even when the device is switched off.

ART: Running time controller

It calculates the total running time. It begins counting as soon as the engine is switched on.

RT: Total running time controller

It calculates the vehicle's running time from the last RESET. It begins to count from when the vehicle starts to move. The data is stored in the memory, even when the device is switched off.

12/24 hour clock

It displays the current time in 12 or 24 hour clock. It indicates the temperature of the environment and engine. The display screen on the upper left shows the environmental temperature. Using an optional temperature sensor, the screen displays the engine temperature. If excessive, the yellow light comes on.

Indicator that engine turn rate is excessive / Warning of gear change due to rpm.

If the engine turn rate is excessive a second red warning light will come on. This function acts as a warning to change gear when a specific number of rpm is reached. The red light flashes when the rpm reaches the established value and stops flashing when the gear is changed.

Adjustment of the multi-function box settings

After confirming each value, the multi-function box will move straight on to the next screen adjustment until the process is complete. If no button is pressed, the multi-function box will return to the initial screen after 15 seconds.

Activation of the adjustment mode

To activate the adjustment mode for the multi-function box settings, push buttons 1, 2 and 3 simultaneously for 3 seconds and then release them.

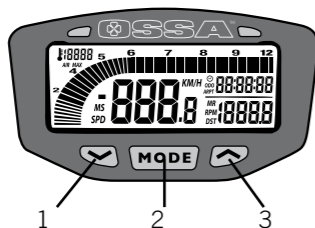

Select the speed unit

To select the speed unit between km/h and m/h, press 1. Confirm your selection by pressing 2.

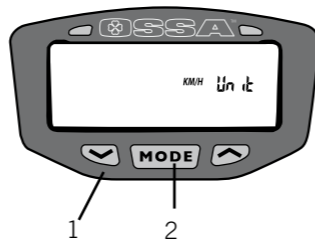

Select the wheel circumference

Enter the wheel circumference by pushing button 1 repeatedly. To move to the next digit, press button 3. Confirm the selection by pushing button 2.

Note: If you don't know the wheel circumference, consult the "Measuring the wheel circumference" section.

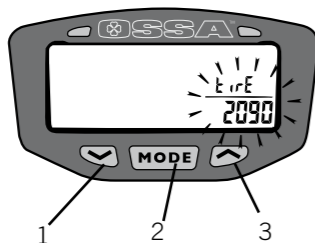

Select the time format

To select the time format change between the 12 and 24, press 1. Confirm your selection by pressing 2.

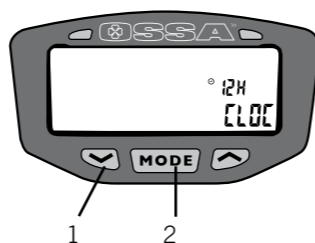

Time adjuster

Set the time by pressing button 1 repeatedly. To move to the next digit, press button 3. Confirm the selection by pushing button 2.

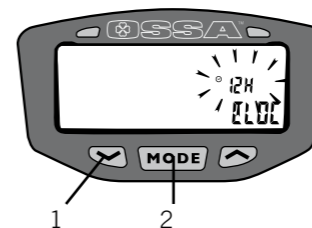

Adjustment of the revolution pulse (PPR)

Note:

This step must only be followed for those vehicles that change the PPR pulse type to a specific turn rate. If you don't know this value, press button 2 to move on to the next screen. Enter the value by pressing button 1 repeatedly. To move on to the next digit, press button 3. Confirm the selection by pushing button 2.



Adjustment of the revolution pulse (PPR)

The indicator receives an electric pulse each time the engine turns (PPR). Default value for 2 and 4 stroke engines: 1 PPR. Enter the value by pressing button 1 repeatedly. To move on to the next digit, press button 3. Confirm the selection by pushing button 2.

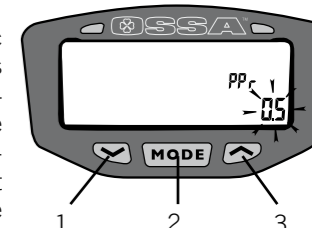

Adjustment of the revolution pulse (PPR)

Note:

This stage must only be implemented if in the previous stage the value 0 was entered. Default value: 1.0. If you don't know this value press button 2 to move on to the next screen. To move on to the next digit, press button 3. Confirm the selection by pressing button 2.

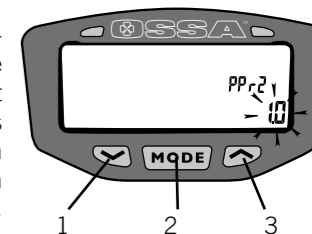

Temperature selector

To select the unit of temperature, either °C or °F, press button 1. Confirm the selection by pressing button 2.

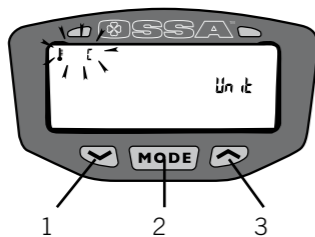
**Danger temperature selector****Note:**

This stage should only be implemented for those vehicles that have an optional temperature sensor. When the motorcycle temperature exceeds the set value, right-hand warning light comes on. Default value: 110°C (230°F).

Enter the value by pressing button 1 repeatedly. To move on to the next digit, press button 3. Confirm the selection by pressing button 2.

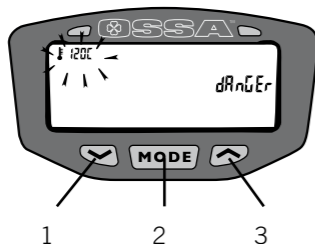
**Warning temperature selector****Note:**

This stage should only be implemented for those vehicles that have an optional temperature sensor. When the motorcycle temperature exceeds the set value, the left-hand warning light comes on.

Default value: 90°C (190°F). Enter the value by pressing button 1 repeatedly. To move on to the next digit, press button 3. Confirm the selection by pressing button 2.

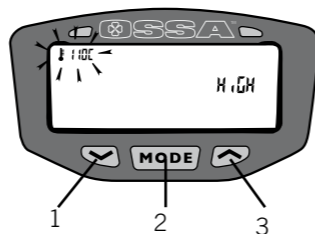
**Gear change turn rate selector**

When the set rate is near to being reached, the left-hand warning light will flash, indicating the need to change gear.

Default value: 6000 rpm. Enter the value by pressing button 1 repeatedly. To move on to the next digit, press button 3. Confirm the selection by pressing button 2.

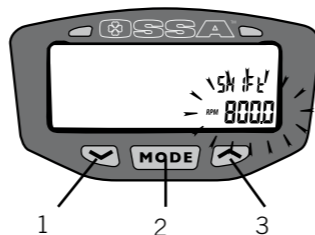
**Dangerous turn rate selector**

When the set rate is near to being reached, the right-hand warning light will flash, indicating that the engine is turning at an excessive rate.

Default value: 10,000 rpm. Enter the value by pressing button 1 repeatedly. To move on to the next digit, press button 3. Confirm the selection by pressing button 2.

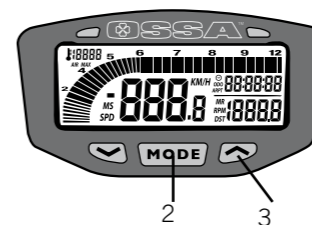
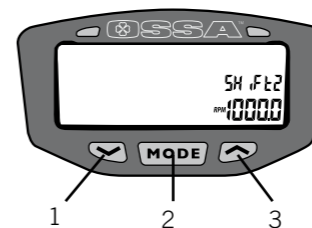
**Setting the indicator functions to zero after each use of the vehicle**

After each use of the vehicle, it's possible to set the following functions to zero, simultaneously:

- Maximum speed
- Distance
- Chronometer
- Maximum temperature
- Maximum turn rate

Confirm that you want to set these functions to zero by simultaneously pressing buttons 1 and 2.

Setting the whole multi-function box to zero

Press the RESET button by using a suitable object. The indicator will boot again, excluding data that corresponds to total accumulated distance and time.

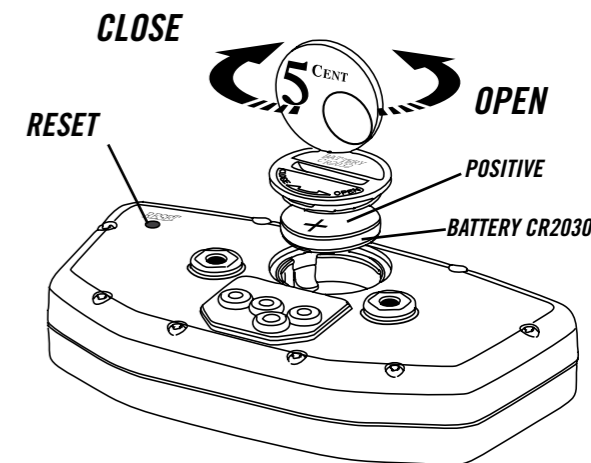
**Internal battery**

The multi-function box works with a 3V internal battery, type CR2032. When the battery tension falls beneath 2.45V, the screen displays the LO indicator. To change the battery, open the lid on the bottom of the indicator by unscrewing it as is indicated in the image, using a coin. Ensure that the positive side of the battery is facing upwards.

Screen Options

The multi-function box displays all information on three different screens. While on, it is possible to see screens 1 or 2. Screen 3 is displayed for three seconds and then returns to screen 1.

To move from one screen to another repeatedly press button 2 ("Mode"). To edit the distance covered (DST) hold down button 3.

Screen 1:

Screen 1 displays the following information:

- Speed, distance covered, time, environmental temperature, tachometer (bar).

Screen 2:

Screen 2 displays the following information:

- Speed, digital tachometer, running time, uptime, engine temperature*, tachometer (bar).

Pantalla 3:

Screen 3 displays the following information:

- Maximum speed, dangerous turn rate, accumulated running time, mileage counter, maximum temperature*.

* optional

Screen Illumination

The multi-function box works by using a 3V internal battery, type CR2032. To change the battery, open the lid on the bottom of the indicator by unscrewing it, as indicated in the image, using a coin. Ensure that the positive side of the battery is facing upwards.

When the multi-function box is powered exclusively by the internal battery, the screen illumination is partially maintained for 3 seconds when the button is pressed.

When it is connected to the 12V vehicle installation, the illumination will be brighter and will remain constant for 20 minutes after the vehicle has stopped.

Sleep Mode

If the multi-function box receives no information for 20 minutes (wheel signal, turn signal or pressed button) the screen will turn off, displaying only the time. When the vehicle moves, or by pressing any button, it will start up again.

Measuring the wheel circumference

Method 1:

Measure the diameter of the front wheel. Multiply the diameter obtained by 3.14. If necessary, convert the measurement into mm by multiplying the obtained figure by 25.4. The measurement obtained corresponds to the measurement of the wheel circumference.

Method 2:

On a smooth and flat surface, put a mark on the side of the tyre and in the area where it is touching the ground. Move forward with the vehicle until the wheel has turned completely once and the mark is on the lowest part again. Put a new mark on the ground at this point. Measure the distance between the two marks on the ground. If necessary, convert the measurement in mm by multiplying the figure obtained by 25.4. The measurement obtained corresponds to the wheel circumference. To obtain a more accurate measurement, the rider should remain on the vehicle when the measurement is taken.

Control Pad

The control pad is located on the left handlebar, within reach of the thumb. This control pad can be used to control the lights, indicators, horn and engine stop.

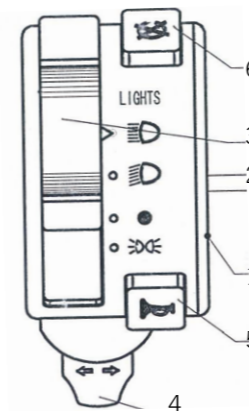

i See the image with information about the control pad.

- 1 – Position lights
- 2 – Cross lights
- 3 - Long range lights
- 4 – Lights for changing direction (left – right)
- 5 – Horn
- 6 – Button to switch off engine

i See the image with information about the control pad.

- 1 – Pilot lamp for change of direction (left – right)
- 2 – Pilot lamp for cross lights
- 3 – Pilot lamp for long range lights
- 4 – Pilot lamp for footrest

The front suspension is made up of a fork that fixes the wheel and the front brake system in place. This fork is formed by the suspension bars that contain the shock absorber spring and the suspension mechanism. They are connected to the upper part where the direction pipe is located, a point of connection between the fork and the chassis. A regulating screw and an air bleed are located on the upper part of each suspension bar (see photo).

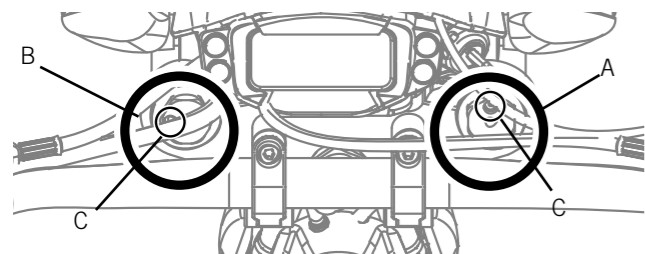

To regulate the extension, use the screw located on the right suspension bar (Fig. A)
 To regulate the compression use the screw located on the left suspension bar (Fig. B)
 Each of the suspension bars also has an air bleed to remove air that accumulates in the inside of the fork stanchion (Fig. C)

i The fork contains oil SAE 5, with 310 cc in the left bar (C) and 310cc in the right bar (R).

The rear suspension is formed by a single shock absorber spring. The preload of this spring can be adjusted by turning the toothed rings that dictate its direction.

i A special key is needed to adjust these toothed rings.

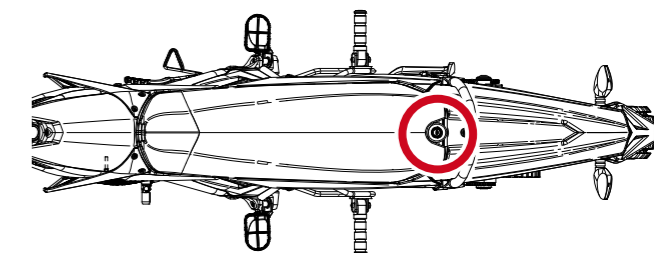
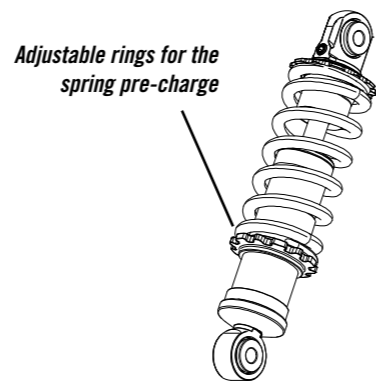

(Fig. 1)

In order to access some parts of the engine or the wiring, you must previously remove the seat.

- 1: First, you must open the rear seat lock with the ignition key.
- 2: Then you must pull the back of the seat upwards and then backwards, as in figure 2.
- 3: To put the seat back on the bike, repeat the process in inverse order.

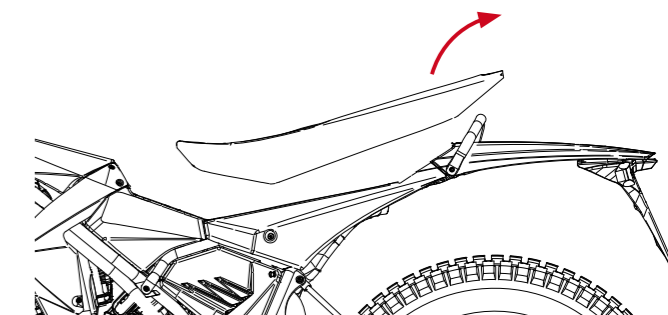

(Fig. 2)

The EXPLORER has an immobilization system for protection against theft.

This system consists of a lock situated in the area of the brake discs on the rear wheel. It is a mechanism that is operated with a key and blocks the rear wheel.



IMPORTANT: this key has a code which is needed for making duplicate copies of the key. This code should be written down in the indicated space on the registration page and series number of this manual.

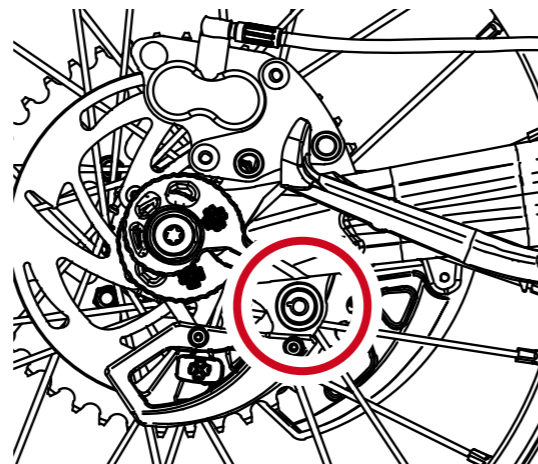

Before starting the motorcycle, you must ensure that the key switch at the right hand side of the headlight is activated. Also, it must be in neutral gear. DO NOT try to start in a gear .

The kick-start pedal is part of the mechanism that is used to kick start the motorcycle mechanically.

To kick start the motorcycle, the kick-start pedal must be separated from the bike and moved outwards. Once separated, place your foot on top and press strongly to turn it counter-clockwise.

It is necessary to ensure that the light signals are working properly, that the tire pressure is correct and the security and control elements (brakes and controls) are in good condition.

i If the motorcycle has been inactive for a long period of time, it is recommended that the kick-start pedal is activated gently 3 or 4 times, without actually kick-starting the motorcycle. This will enable the engine to move which will help when kick-starting it. If the motorcycle has been inactive for a very long period of time, change the oil and petrol because they might have become degraded. This could affect the motorcycle's performance.

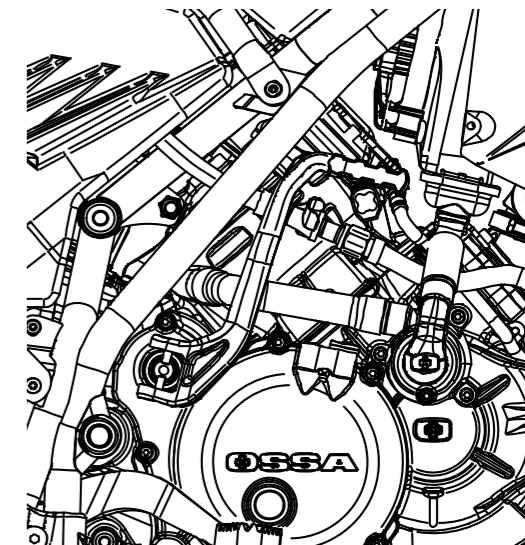



The engine of this motorcycle works with a mixture of unleaded petrol and 2S oil, 100% synthetic in a 0.9 proportion.



The Explorer has two fuel tanks, one forms a structural part of the chassis and is located on the front inside part. The other one is made of polyamide plastic and is located in the classic position on the frame. To fill up with petrol, open the upper fuel tank lid, situated on the upper part, by unscrewing in an anti-clockwise direction.



It's recommended that a hose or funnel is used to fill up to avoid spilling the petrol. This is especially important if the motorcycle is hot. DO NOT fill up with petrol when the motorcycle is turned on.

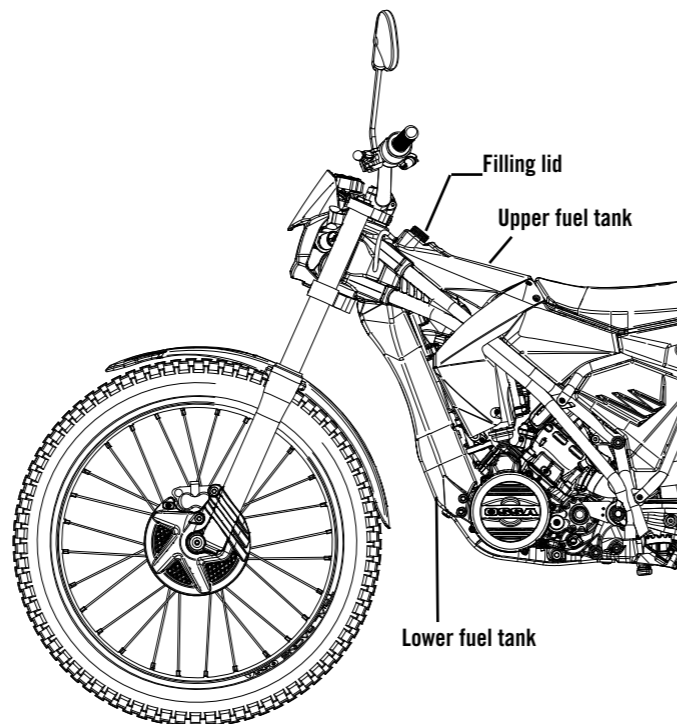

In order to access some parts of the engine or the wiring, you must previously lift the upper fuel tank.

- 1: First you must remove the seat. (see page 25, Seat)
- 2: Unscrew only the four upper screws of the side tank pannels.
- 3: Disconnect the air hose located in the front of the upper fuel tank.
- 4: Disconnect the conector that connects both fuel tanks.
- 5: Unscrew the upper tank central screw (which is located where indicated with number 5).
- 6: We proceed to lift the tank from the front, pivoting backwards.



When performing the operation No. 4 (Disconnect the connector that connects the two fuel tanks), You must mind the existence of residual fuel in the quick connector.



In operation No. 2 (Unscrew only the four upper screws of the side tank pannels) never release the screws that attach the pannels to the radiator, as it could pierce it or eventually damage the threads.

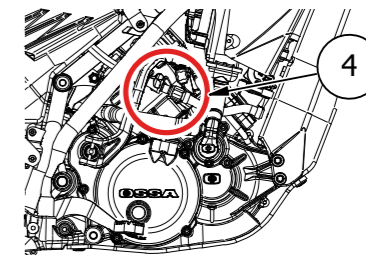
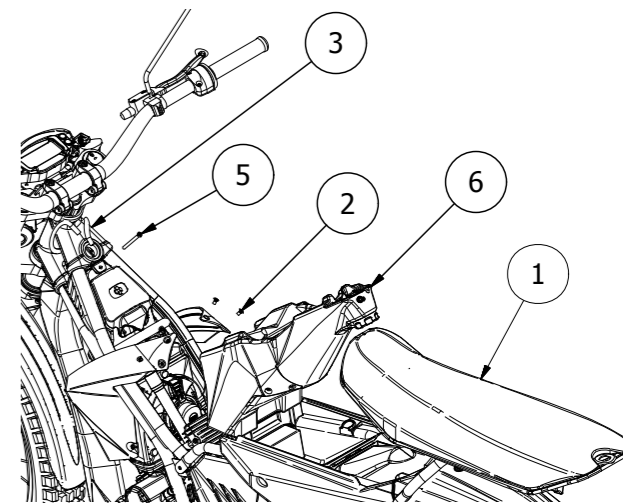

Section 2 – Maintenance and basic operations



Item	Check / Inspect	Adjust	Replace / Change	Clean	Grease / lubricate
Air filter	Each use	–	When damaged	Each useE	ach wash
Transmission oil	30 Hours	–	60 horas	–	–
Refrigerant	Each use	–	Each year	–	–
Sparkplug	Each use	30 Hours	60 Hours	15 Hours	–
Reed block	30 Hours	When necessary	When damaged	–	–
Cylinder	60 Hours	–	Each year	–	–
Clutch	Each use	–	When damaged	–	–
Clutch discs	–	–	When damaged	–	–
Exhaust	Each use	–	When damaged	–	–
Silencer	–	–	When damaged	–	–
Wire and throttle grip	Each use	When necessary	When damaged	When necessary	Each wash
Change / kick-start pedal	Each use	When necessary	When damaged	When necessary	Each wash
Piston and piston ring	60 Hours	–	Each year	–	–
Radiator tube and connections	Each use	When necessary	–	–	–



Item	Check / Inspect	Adjust	Replace / Change	Clean	Grease / lubricate
Rear shock absorber	Each year	–	Every 2 years	–	–
Front suspension	Each year	When necessary	Every 2 years	–	–
Front suspension lubricant	–	–	60 Hours	–	–
Brakes	Each useW	When necessary	hen damaged	–	–
Swing arm and linkage arms	Each useW	–E	hen damaged	Each use	ach wash
Secondary transmission	Each use	When necessary	When damaged	Each use	Each wash
Steering bearings	Each use	–	When damaged	–	Each wash
Wheel bearings	30 horas	–	When damaged	–	Each wash
Brake discs	Each use	When necessary	When damaged	–	–
Tyres	Each use	–	When damaged	–	–
Front/rear tyre	Each use	–	When damaged	Each use	–
Front/rear spokes	Each use	5 Hours	When damaged	Each use	–
ChassisE	ach use	–E	When damaged	ach use	–
Fuel tank	Each use	–E	When damaged	ach use	–
Screw, nuts and fastenings	Each use	When necessary	When damaged	Each use	–
Crankcase protector	–	First useE	When damaged	ach use	–
Protective stickers	Each use	–	When damaged	–	–

The clutch lever is located on the left handlebar grip and is used to activate the clutch mechanism to change gear.

The front brake lever is located on the right handlebar grip and is used to activate the brake caliper of the front brake.



It's important that the levers and rear brake pedal have a 3 mm give.

It's important that the levers can be easily activated by the rider while he/she is riding the bike, using the index and middle fingers.

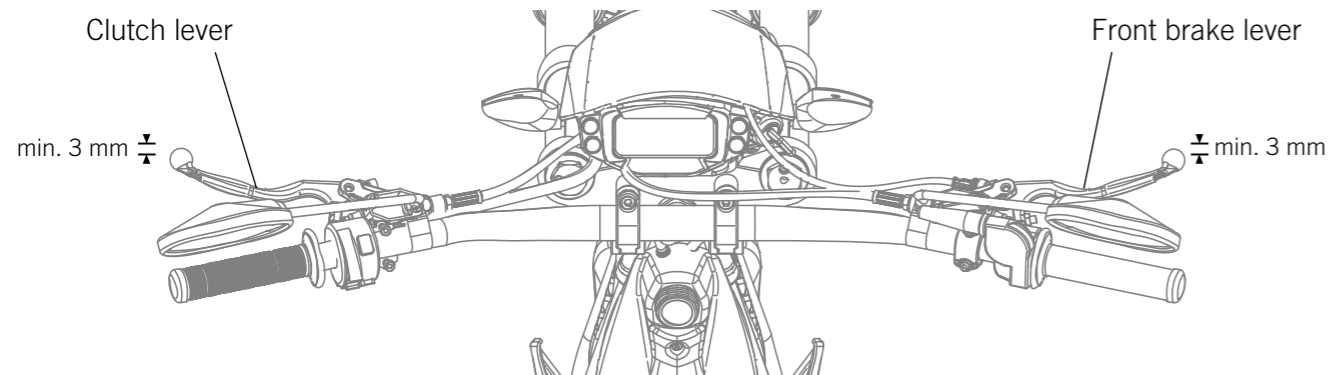

Check the condition of the motorcycle's electrical connections in order to ensure they are maintained in good working order.

As seen in the image on the right, these are located at the left side of the cylinder, between the steering bar and the front headlight, and in the fuel system apparatus.



Carry out a regular and thorough maintenance of your motorcycle. Always use original spare parts and top quality products to ensure that it works correctly.

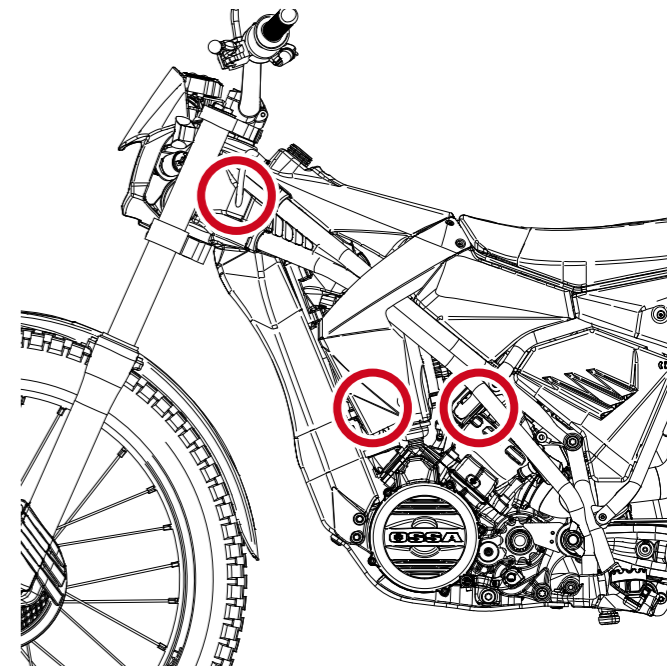

Air filter. Cleaning and maintenance

The air filter should be controlled periodically. Lift the upper fuel tank, as you can see in the image on page 29, in order to access the filter box. Remove the filter rubber cap, unscrew the upper part of the filter (not necessary to use tools) and take out. To clean, use water and detergent, leave to dry and then lubricate with a special liquid for filters. Reassemble using the steps outlined previously but in reverse. Make sure that the parts are put in their correct positions.



Carry out regular and thorough maintenance of your motorcycle. Always use original spare parts and top quality products to ensure that it works correctly.

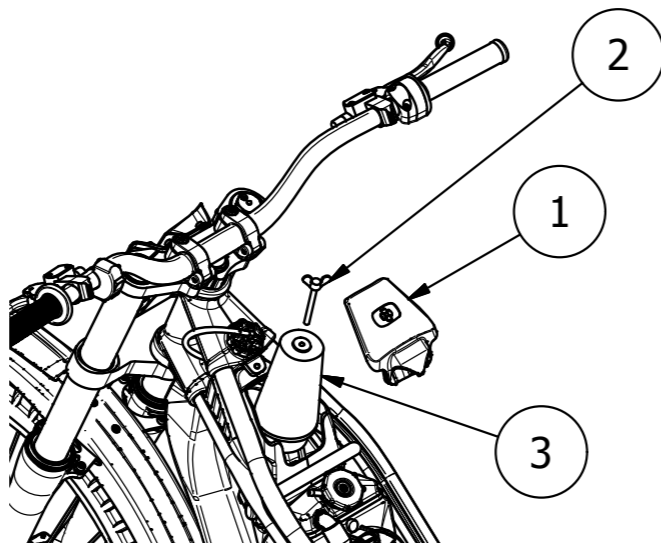

The radiator contains the engine refrigerant. To fill up with or add refrigerant to the radiator, locate the tank lid. To locate this lid, detach the air filter lid (see page 36 - Air Filter). Once the filter lid is detached, the radiator lid is visible. Unscrew the lid and pour in refrigerant.



ATTENTION: Use gloves. Do not open the lid if the engine is hot. This could cause burns. Avoid contact of the liquid with the eyes, mouth or nasal passage. Do not ingest. In the event of this happening, follow the product instructions and consult a doctor.

The radiator has an electric fan to force air through it, as can be seen in the image below.

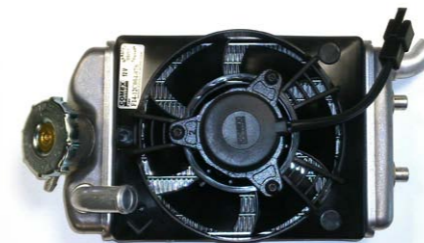

To fill the radiator, special coolant should be used -30°C.

To ensure that the motorcycle works correctly, periodic controls must be carried out to check the coolant levels. This will ensure that the motorcycle is running at an optimum temperature.



Always use special refrigerant for light alloy engines.

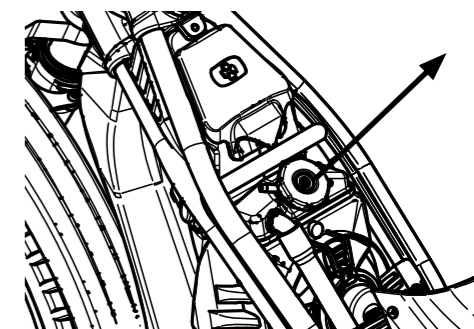

To access the sparkplug detach the right side cover (see fig. 1). Once the cover has been removed, the motorcycle's electrical system can be accessed. Carefully but firmly, pull away the hood that provides current, leaving the upper part of the sparkplug exposed. Using a special sparkplug tool, unscrew it and take it out from the right side of the motorcycle (see fig. 2).

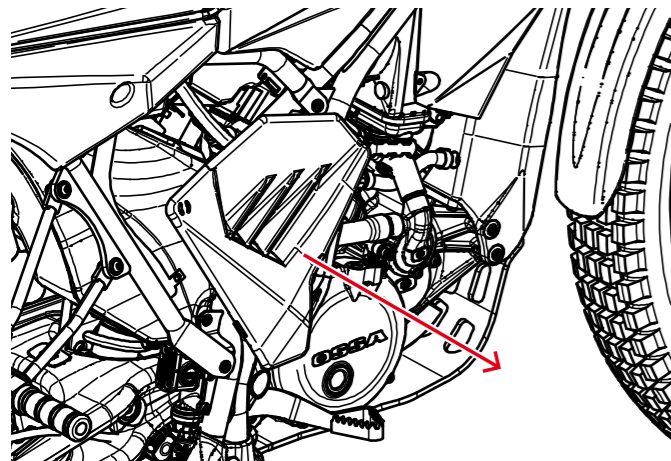

The sparkplug should be checked regularly and a spare sparkplug should be carried at all times in case it comes off. The sparkplug can accumulate charcoal and dirt with use. For this reason, it can be removed and cleaned so that it lasts longer.

! Observe the distance between the electrode and the arch. This distance should be 0.5-0.6 mm. **NOTE:** The sparkplug should not be handled if the motorcycle is hot.

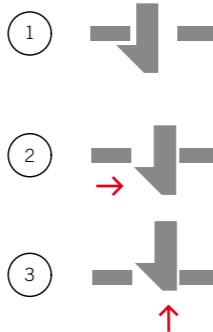
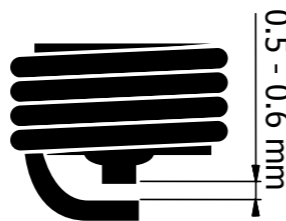

To extract the side cover, 1: bend it slightly until releasing one of the fixing snaps. 2: move the cover laterally, without turning it, to release the other fixing snap. 3: pull the cover out.

The transmission chain transmits the engine's movement to the rear wheel. To ensure that it works correctly, it should be checked.

! The axle has easily adjustable eccentrics for tensing the chain and centring the wheel.

! The chain hook should be positioned in an opposite direction to the gear, as can be seen in the photo.

! The chain tension should permit 2 cm of oscillation in the chain tension adjuster.

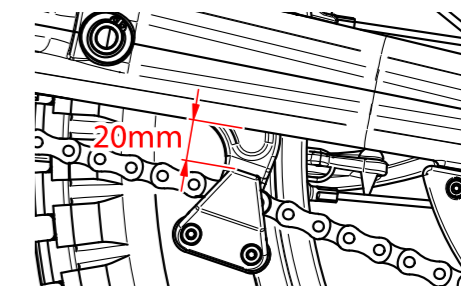
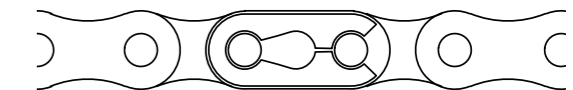
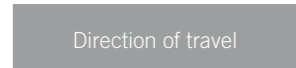
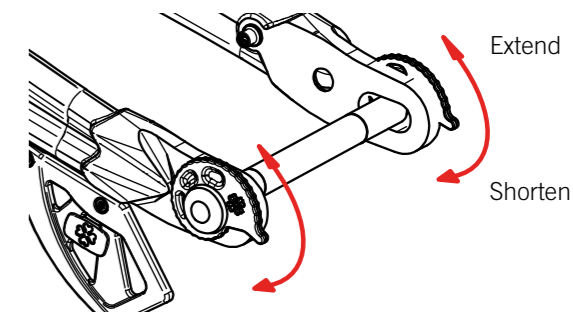

Cleaning the motorcycle and lubricating the mobile parts will help protect the motorcycle and guarantee that it works better.



If using a high pressure hose to clean the motorcycle, bear in mind that the water pressure might rip off the stickers or cause damage to the motorcycle.



Take care NOT to accidentally lubricate the brake caliper or brake pads. If this happens clean off the lubricant and carry out controlled braking until the brakes work correctly again.

Lubricate using specific products::

1. Transmission chain
2. Clutch and brake lever joints
3. Gear lever joints
4. Rear brake pedal joints and bearings
5. Footrest brackets and springs
6. Engine kick-start pedal joints
7. Gas handle (right grip)



Use specific lubricants for each part of the motorcycle.

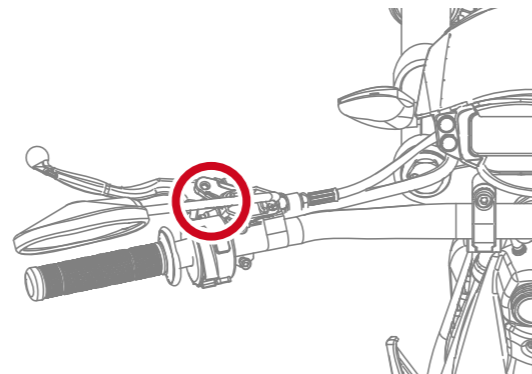

Clutch and brake lever joints



The chain drive should always be well lubricated. Check it each time the motorcycle is used and apply lubrication when necessary.



The chain must be lubricated using special oil for chain

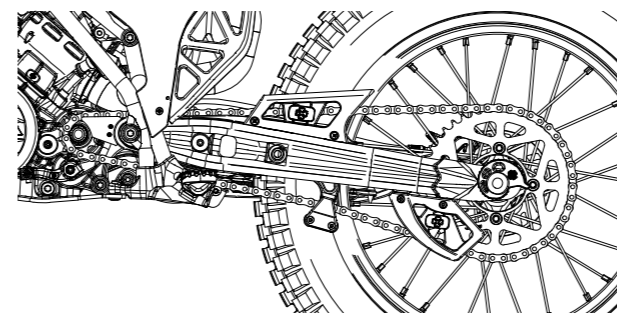

Chain drive

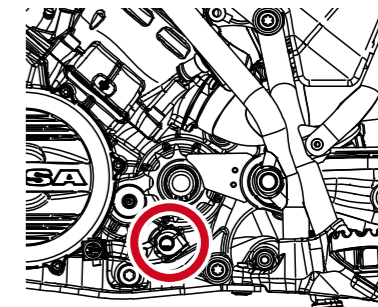

Gear change lever joints

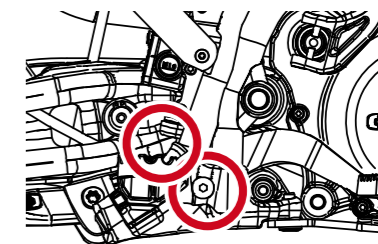

Rear brake pedal Chain drive joints and bearings

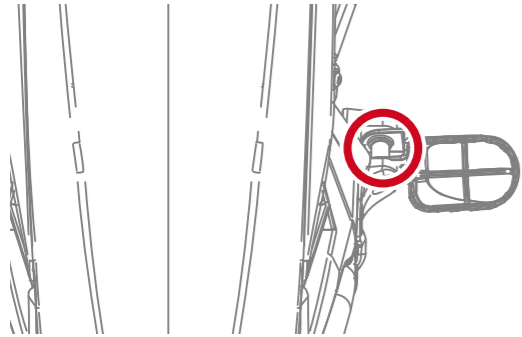

Footrest bracket and springs

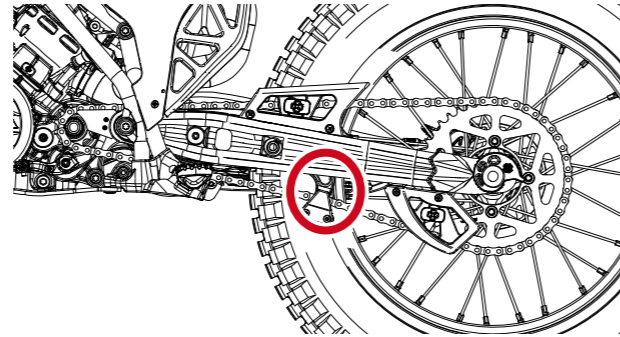

Chain drive and tension adjuster springs

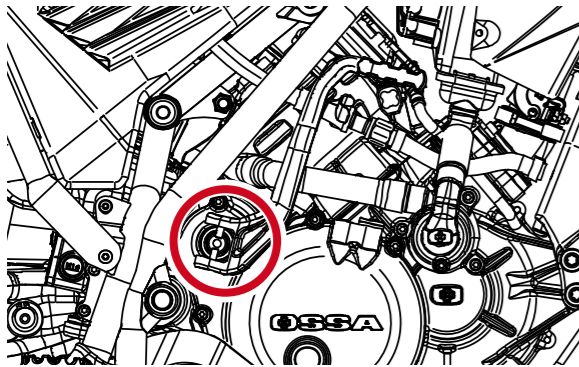

Engine kick-start pedal joints

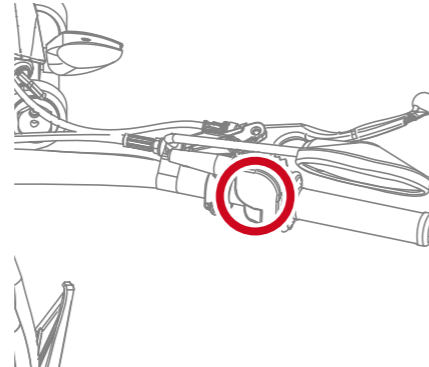

Gas handle (right grip)

Pressure and condition

To ensure that the motorcycle works correctly, it's very important to check the tyre pressure and that the wheels are in good working condition before each use. Using tyres that are in a good condition will mean that the motorcycle is capable of performing to the best of its ability. It also ensures that trial riding is safer and more efficient.

i Front tyre: 2.75x21"
Rear tyre: 4.00x18"

i Front tyre pressure: On-road: 0.9 bar
Off-road : 0.55-0.60 bar
Rear tyre pressure: On-road : 0.9 bar
Off-road : 0.50-0.55 bar

! NEVER forget to periodically check the tyre pressure to ensure that the tyres have a good grip.



Tyre in good working condition



Tyre in bad working condition

Filling and draining the crankcase

Crankcase oil is used for lubricating the change pedal and the clutch. Check the oil level with the indicator located on the lower part of the clutch cover, which is on the right side of the engine. The oil level should be lower than the indicated maximum level.



! The oil level should be checked when the motorcycle is in an upright position and on a flat surface. The motorcycle should be cold. If it is not cold, wait some minutes until it goes cold.

To add oil, remove the cap (A) located on the top of the clutch cover (D). Use a funnel to add the oil, NEVER filling above the Maximum level. Replace the cap. If you fill above the Maximum level, oil must be removed. To remove oil from the hood, place a receptacle under the motorcycle and remove the lid (B) located on the side of the hood, and the screw (E), and lean the bike over in both directions to ensure that no oil remains inside the hood.

! **IMPORTANT:** Clean the plug and change the sealing washer each time the oil is changed.

i The crankcase has a 450cc oil capacity. 2T 100% synthetic oil should always be used.

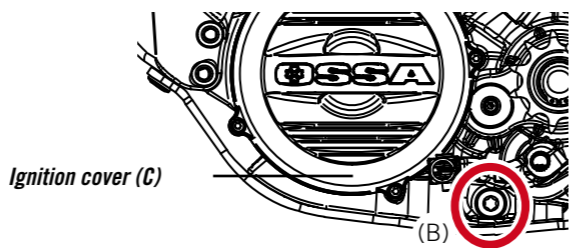
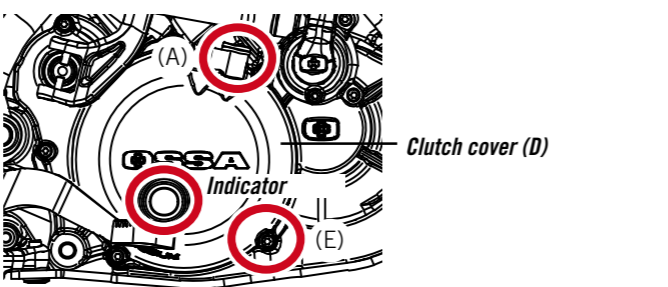

The brakes permit precise and controlled riding. It is necessary to check them in order to ensure that they work correctly.

! Wear on the front and rear brake pads must be periodically controlled so that the brakes work effectively.

! The oil level can be checked using the indicator on the front handle and on the rear pump tank. The oil level should be situated between the min and max values.

! To remove surplus air from the break circuit, the calipers are equipped with air bleeds. See image.

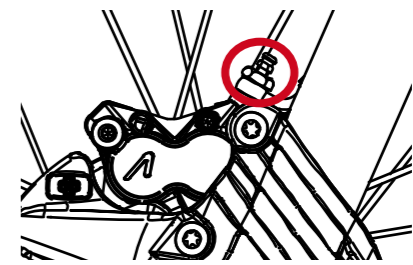
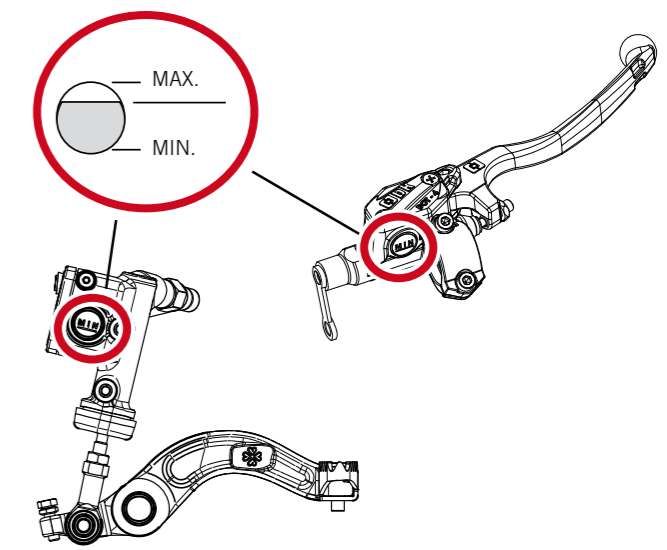



These grids show the tightening torques of different parts

FRAME

Part	Nm
Front wheel axle	40 - 50
Swing arm to frame fixation	70
Upper shock absorber fixation	40 - 50
Lower shock absorber fixation	40 - 50
Linkage arm fixation	5 - 6
Handlebar	25
Front brake and clutch levers	8
Cooler fixation	8
Front fender bridge	12
Brake pedal	25 - 30
Muffler fixation	25 - 30
Rear wheel axle	80 - 90
Rear brake caliper fixation	25
Front brake caliper fixation	25
Exhaust pipe fixation	8 - 9
Engine fixation	22 (F) 30 (R)
Rear brake pump fixation	5 - 7

ENGINE

Part	Nm
Sparkplug	25 - 30
Ignition fixation	8 - 9
Clutch fixation	7 - 8
Cylinder screws	25
Reed valve screws	8 - 9
Pressure plate fixation	3 - 4
Water pump cover fixation	8 - 9
Clutch cover fixation	8 - 9
Flywheel fixation	40
Flywheel cover	8 - 9
Oil draining plug	30
Kickstart pedal screw	12 - 13
Gear lever screw	8 - 9
Cylinder head screws	8 - 9

Storage

If the motorcycle is to be stored for a long period of time, the following procedure should be followed to ensure that it is stored correctly.

- Clean the motorcycle as much as possible because dirt can cause the deterioration of components.
- Turn on the engine for a few minutes to warm up the transmission fluid and then drain. (see section on draining fluid).
- Fill up with new transmission fluid.
- Empty the fuel tank (petrol degrades over time).
- Lubricate the chain and all wires.
- Apply oil to non-painted metal surfaces to prevent rust.

Avoid putting oil on the brakes and rubber parts.

- Wrap the outside of the exhaust pipe in a plastic bag to prevent rust.

- Position the motorcycle so that the wheels don't touch the ground to prevent possible tyre deformation. If this is not possible, cardboard can be placed underneath the wheels.

- Place a cover over the motorcycle such as canvas, plastic or material. This will protect the motorcycle from dust and other external factors. Avoid storing the motorcycle outside, or in direct sunlight.

Starting the motorcycle again

To start up the motorcycle after a period of inactivity, the following procedure should be followed:

- Remove the plastic covers that were placed over the motorcycle before storing, including the exhaust pipe and those parts that had special protection.
- Tighten the sparkplug.
- Fill up the fuel tank with new petrol.
- Carry out general lubrication.
- Check tyre pressure.
- Leave the engine running for some minutes to warm up the engine oil.



In the event of breakdown always take the motorcycle to a specialist mechanic

PROBLEM	POSSIBLE CAUSE	POSSIBLE SOLUTION
The engine won't start	- Long period of engine inactivity	- Change the old petrol for new petrol
	- Sparkplug dirty or wet	- Dry / clean or change the sparkplug
	- General fuse damaged	- Change general fuse
	- Bad electrical connection	- Check electrical connections and position correctly - Take the motorcycle to a specialist mechanic
The engine starts and then stops	- Lack or deterioration of petrol	- Fill the fuel tank with new petrol - Take the motorcycle to a specialist mechanic.



In the event of breakdown always take the motorcycle to a specialist mechanic

PROBLEM	POSSIBLE CAUSE	POSSIBLE SOLUTION
The motorcycle is unstable	- Wire makes it difficult for the handlebar to turn	- Move wire or loosen it a bit
	- Steer axle screw is very tight	- Loosen the steer axle screw
	- Steering bearings are damaged or with wear	- Replace steering bearings
	- Steer axle bent	- Change the steer axle. Contact an officially registered mechanic
The shock absorption is too hard	- Excessive oil on front fork	- Remove surplus oil until it reaches the correct level.
	- Oil too viscous on front fork	- Drain fork oil and fill up with viscous oil.
	- Front fork bent	- Change the front fork. Contact an officially registered mechanic.
	- Rear shock absorber badly adjusted	- Adjust the rear shock absorber
	- Tyre pressure too great	- Check the pressure of the tyres



In the event of breakdown always take the motorcycle to a specialist mechanic

PROBLEM	POSSIBLE CAUSE	POSSIBLE SOLUTION
The shock absorption is too soft	- Too little oil in front fork	- Add oil to the fork until it reaches a sufficient level
	- Front fork oil not sufficiently viscous	- Drain fork oil and fill up with suitably viscous oil
	- Front fork bent	- Change the front fork. Contact an officially registered mechanic.
	- Rear shock absorber badly adjusted	- Adjust the rear shock absorber
The motorcycle makes abnormal noises	- Chain badly adjusted	- Adjust chain
	- Chain wear	- Change chain and sprockets
	-Rear sprocket teeth wear	-Change rear sprocket
	- Insufficient chain lubrication	- Lubricate chain
	- Rear wheel badly adjusted	- Align rear wheel. Contact an officially registered mechanic.
	- Front fork with insufficient oil	- Add oil to the fork until it reaches a sufficient level.
	- Front fork spring weak or broken	- Replace front fork spring
	- Brake disc wear	- Replace brake disc
- Brake pads badly positioned or crystallised	- Change position of brake pads or replace them.	



In the event of breakdown always take the motorcycle to a specialist mechanic

PROBLEM	POSSIBLE CAUSE	POSSIBLE SOLUTION
The motorcycle makes abnormal noises	- Cylinder damaged	- Replace the damaged cylinder
	- Supports, screws or nuts are not properly fastened	- Check and adjust using suitable torque wrench
	- Tyres wear, swing arm or its needle bearings wear	- Change worn parts for new parts
	- Wheel rim not centred	- Centre wheel rim
	- Wheel not centred	- Check the tension of the spokes and readjust
The handlebar vibrates	- Lack of engine oil	- Check and add engine oil
	- Steer axle with excessive tolerance	- Tighten the handlebar support and the steer axle nut using suitable torque wrenches.
	- Handlebar support loose, steer axle nut loose	- Tighten the handlebar support and the steer axle nut using suitable torque wrenches.



In the event of breakdown always take the motorcycle to a specialist mechanic

PROBLEM	POSSIBLE CAUSE	POSSIBLE SOLUTION
The motorcycle tends to lean to one side	- Bent chassis	- Change chassis. Go to specialist mechanic
	- Steering badly adjusted	- Adjust steering. Go to specialist mechanic
	- Steer axle bent	- Change steering axle. Go to specialist mechanic
	- Front fork bent	- Change front fork
	- Wheels badly centred	- Align wheels
The brakes don't work correctly	- Disc wear	- Change disc
	- Loss of brake fluid	- Check brake circuits. Change if damaged or broken
	- Brake fluid in bad condition	- Drain brake fluid and replace with new fluid recommended by a mechanic
	- Pump piston broken	- Replace the pump piston
	- Brakes badly adjusted	- Adjust brakes

Standardisation components



Each of the registered elements should be part of the vehicle. In the event of breakages, loss or bad functioning, it is recommended that you go to an official OSSA mechanic to remedy the problem.

Your Ossa EXPLORER is standardised in compliance with EU regulations. It adheres to all standardisation requirements EURO-3 regulations.

The obligatory elements to be registered for driving on public roads and for passing the vehicle's MOT are listed below.

The elements to be registered among others are identified with a specific mark and registration.



Each of the registered elements should be part of the vehicle. In the event of breakages, loss or bad functioning, it is recommended that you go to an official OSSA mechanic to remedy the problem.

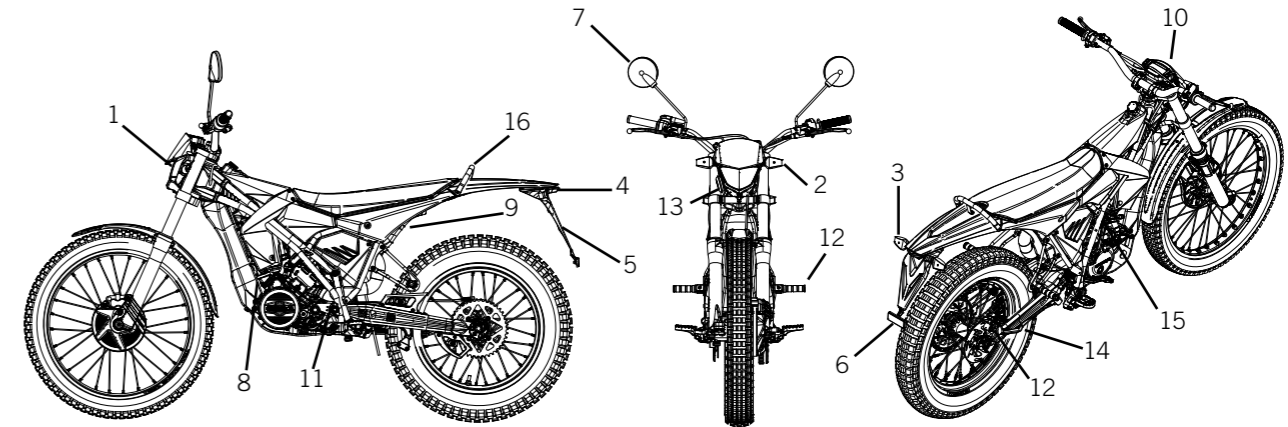

- 1. Front headlight
- 2. Front indicators
- 3. Rear indicators
- 4. Rear pilot
- 5. License plate support
- 6. Reector
- 7. Mirrors
- 8. Manufacturer's plate
- 9. Exhaust system
- 10. Speedometer

- 11. Pinion output
- 12. Lock
- 13. Horn
- 14. Kickstand
- 15. Throttle limiting bolt
- 16. Handle
- 17. Passenger footrests (in the bike homologated for 2 people).



Element		Homologation identification
1. Front headlight		11/12-e9*97/24*97/24/*4367*00
	Front position lamp	R55.00.14839
	Driving beam	R113.00.14839
	Passing Beam	R113.00.14839
2. Front indicators		11001200e94367
3. Rear indicators		
4. Rear pilot		e13*50 R00*50R00*12448*00
5. License plate support		
6. Reflector		IA.E9.02.01269
7. Mirror		L-e9*80/780*80/780*0143*01
8. Manufacturer plaque		
9. Exhaust system		
10. Speedometer		
11. Pinion output		z=11
12. Lock		
13. Horn		e13*28R00*28R00*0037*00
14. Kickstand		
15. Throttle limiting bolt		
16. Passenger handle		
17. Passenger footrests (in the bike homologated for 2 people).		

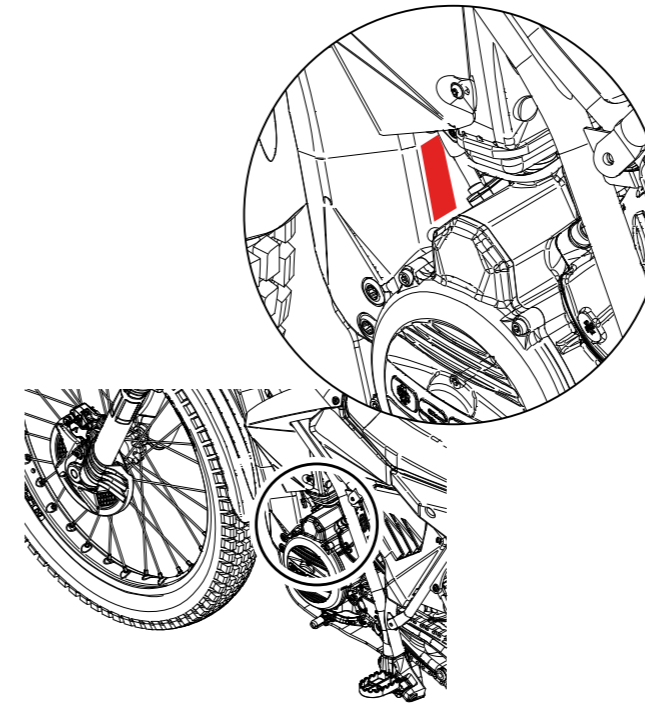

Manufacturer's plate

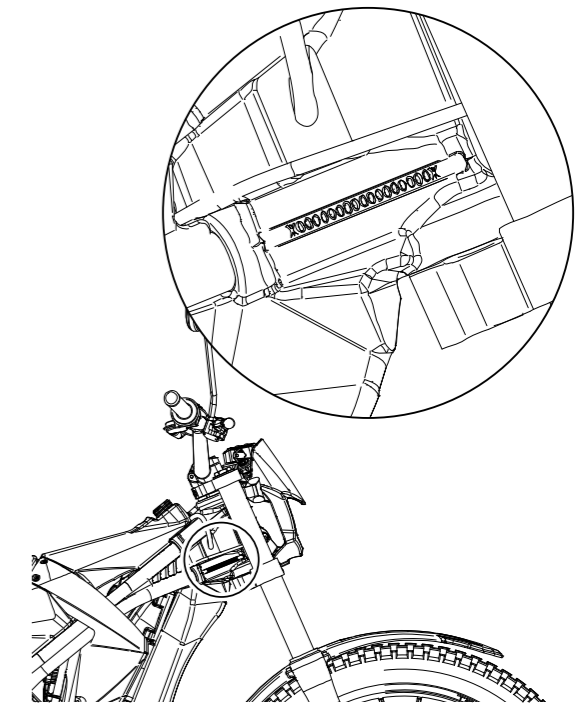

Serial number

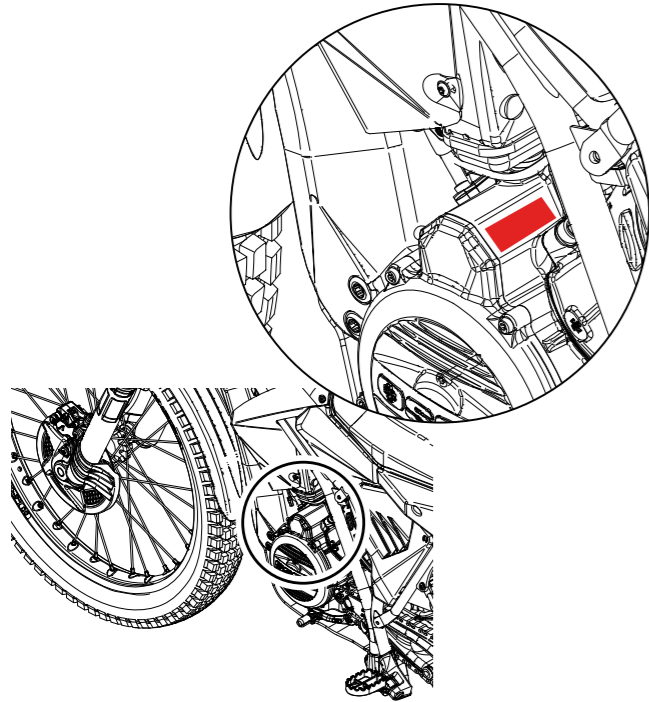

Engine number



The key number can be found under the red cover.

Key number

Warranty

Terms and conditions of the warranty

The warranty is associated to the product indicated in the “CERTIFICATE OF DELIVERY AND INSPECTION”, which shall be filed out by authorised staff in OSSA FACTORY, SL (hereinafter referred to as OSSA). It is valid for those countries indicated on page 33. The warranty is only applicable to motorcycles that have been initially imported via the official OSSA importer for your country, meeting all the regulatory requirements and authorisations of each country. This warranty does not limit or adversely affect consumers’ legal rights and guarantees by virtue of any obligatory national regulations. It is independent of the legal warranty provided by the official dealer.

Name and address of guarantor

The guarantor is the commercial organisation OSSA FACTORY, SL, Crta Antiga d’Amer, nave 12, Pol. ind. Domeny, 17007 Girona (Girona).

Consumer’s rights as warranty holder

With this document OSSA provides the final user with a guarantee that the motorcycle manufactured by OSSA is free from defects and that it has been manufactured in compliance with the strictest quality control regulations. Therefore, the warranty extends to both the parts and the labour costs in the event of any repair provoked by faulty materials or manufacture detected in a new motorcycle. This is applicable for the time period stipulated within the warranty without limitation, except for those that are listed in this manual. The maintenance and service requirements indicated by OSSA must have been adhered to, in compliance with the conditions herewith, for the warranty to be valid.

OSSA is held responsible before the purchaser in the event of the product’s non-compliance at the time of product delivery. When the product is non-conforming, the purchaser must decide whether they want the product to be repaired or replaced. The purchaser’s decision, when notified to the seller, is binding for both parties with one sole exception: if the cost of reparation or replacement is disproportionate to the product’s value, the most reasonable solution will be taken into account. Rectification considered as disproportionate is that which implies costs for the seller which are not reasonable in contrast with the other means of rectification. This takes into account the value the product would have if the non-compliance did not exist, as well as the relevance of the non-compliance and if the alternative means of rectification could be carried out without any inconvenience.

The repair is disproportionate when it is uneconomic, or when the reparation is more expensive than the value of the product. If this occurs, the purchaser can choose between a price reduction or contract resolution. Resolution is not permitted when the non-compliance is insignificant.

Regulations for repairs, product replacement, price reduction or contract resolution:

1. It will be free for the purchaser.
2. It will be carried out in a reasonable time period.
3. In the six months following delivery of the repaired product the seller will be answerable for those faults which necessitated the repair. When defects occur of the same origin as those initially repaired, it will be presumed that it is the same fault.
4. If, after the product has been repaired, the product still has faults while the warranty is in force, the purchaser can choose between a replacement, a price reduction or refund. If the purchaser selected a product replacement, they can request a repair – always while the cost of this repair is not disproportionate – a price reduction or refund.
5. The seller is not obliged to replace fungible or second hand goods.
6. The price reduction will be proportional to the difference between the value that the product would have had on delivery if the fault did not exist and the value that the product had at the time of delivery.
7. In the event of it being impossible for the purchaser to address the seller for the product’s non-compliance with the purchase agreement, they will be allowed to claim directly to the manufacturer in order to obtain a replacement or product repair.

PERIOD OF WARRANTY

OSSA is answerable for faults that appear over a two-year period from the product delivery, but if the non-compliance shows up after the sixth month, the purchaser must demonstrate that the fault was present at origin and existed when the product was delivered.

Complaints made for the non-compliance of that which is set out in the warranty must be done within a six month period from when the warranty ends.

Complaints will not be accepted after three years from the product delivery, which is understood to have been made on the date that appears on the "CERTIFICATE OF DELIVERY AND INSPECTION" or on the invoice if a later date is shown.

ACTIVATING THE WARRANTY

We request that you make an appointment with the OSSA sales representative that sold you the motorcycle, or with any authorised OSSA sales representative, providing this warranty manual. The OSSA dealer is under obligation to repair or change, at the discretion of OSSA, any part that is faulty due to either the material used or manufacture process.

WARRANTY FOR SPARE PARTS AND/OR ACCESSORIES

This warranty covers the repair or exchange, at the discretion of OSSA, of any original part due to faulty material or fabrication. The materials and/or labour will be free of charge. Other damages are not included in the warranty, nor are repairs included that appear due to the replacement of the original part. In any case you must certify that the attached table has been duly filled out.

EXCEPTIONS TO THE WARRANTY

The OSSA warranty does not cover the following items:

- a) Damages that arise from not carrying out periodical revisions as stipulated by OSSA.
- b) Damages due to repairs or revisions carried out using methods that have not been specified by OSSA.
- c) Damages due to using the vehicle in races, rallies or other similar competition sports.
- d) Damages due to the practice of functions that are not indicated in the Owner's Manual using the motorcycle beyond those limits or specifications indicated by OSSA (maximum load, passenger capacity, speed of motor and others)
- e) Damages due to the use of parts that are not original or not recommended by OSSA, or the use of fuel, lubricant and compound liquids with specifications that are different to those indicated in the Owner's Manual.
- f) Damages due to modifications that are not approved by OSSA (motorcycle preparations, modifications for increased vehicle performance, light reduction, increases and other changes).
- g) Damages due to the vehicle's aging (natural decolouration of painted or chrome surfaces, peeling and other types of deterioration).
- h) The replacement or repair labour with non-original OSSA parts, or that are assembled by staff not authorised as part of the Official OSSA Post-Sales Service or as OSSA dealers.
- i) Damages due to incorrect storage or transportation.
- j) Damages due to uses that disregard traffic regulations and damages due to accidents.
- k) Spare parts that need to be replaced frequently.

OSSA does not offer a guarantee for parts or fluids that have deteriorated due to use.

The parts or elements mentioned below are not covered by the warranty except when it is necessary to replace them during a repair carried out under warranty.

Parts

Spark plugs, fuel and oil filters and their components, transmission chains, air filters, engine sprockets, back crown gears, disk brake and break pads, clutch disks, light bulbs (except for those that are sealed), fuses, belts, tyres and inner tubes, wires and other rubber and/or tire parts specified by OSSA.

Fluids

Lubricants (such as oil, grease, etc.), and fluids for functioning (for example, refrigerant liquid for the radiator, break and gear fluids, transmission fluids, suspension oil, etc).

- l) Cleaning: inspection, adjustments and other elements of periodical maintenance.
- m) Additional costs on top of warranty service, including: notifications, accommodation, maintenance and other costs due to breakdowns in isolated places. Compensation for wasted time, commercial losses or hire costs of a substitute product during the adjustment period.
- n) Any part replaced under warranty will become the legitimate property of OSSA. The parts replaced during the period of warranty will be guaranteed for the time remaining for the substituted part. OSSA reserves the right to introduce modifications and improvements it deems appropriate for all its models.
- o) OSSA does not guarantee repairs for noise, vibration, oil filtrations and other elements that don't affect the product quality, functioning and performance.

MAINTENANCE AND SERVICE

It is your responsibility to ensure that the services are carried out on your motorcycle within the specified time periods and that the services are correctly registered. This means that your motorcycle will receive all the benefits of the OSSA warranty.

It is recommended that the routine service is carried out by an authorised OSSA dealer where the motorcycle was purchased, where both you and your motorcycle are known.

Under normal circumstances, periodical revisions reduce overall maintenance costs.

If you need to use the warranty service, please contact your authorised OSSA dealer immediately and make an appointment so that the necessary work can be carried out.

It is recommended that periodical motorcycle services are planned in advance.

LOOKING AFTER YOUR MOTORCYCLE

Inspect your motorcycle on a daily basis before driving.

The Owner's Manual contains a list of things to be checked. These inspections will help avoid problems.

Remember that minor adjustments are made more easily at home, rather than on the road.

As well as improving the motorcycle's appearance, thorough cleaning (take care when using pressure or steam cleaning equipment as it can damage the paint and lacquer of the product's finish) provides the perfect opportunity for inspecting your motorcycle.

The appearance and value of your motorcycle depends greatly on how it is looked after.

It is important to clean your motorcycle periodically during the winter because, if not, salt on the roads can cause uncovered metal surfaces to deteriorate.

Procedure for obtaining repairs under warranty

If your motorcycle needs a repair to be carried out under warranty, it should be taken to your official OSSA dealer where the repair will be made (YOU ARE RESPONSIBLE FOR THE TRANSPORT COSTS TO AND FROM THE DEALER).

Ossa recommends that you go to the dealer where your purchase was made. However, you can go to any Ossa dealer for repairs to be carried out under guarantee.

This guarantee provides you as a consumer with specific legal rights. You may also have additional consumer rights that vary depending upon which country you are in.

If one of the afore-mentioned terms is invalid due to regional or federal laws, all other terms stipulated in this warranty continue to be valid.

We recommend that you stay in contact with your OSSA dealer so that you can receive help, advice and information about your new motorcycle, as well as information about the new products launched by OSSA Factory, SL.

We aim to provide full customer satisfaction. If the service you have received is not adequate, we would ask you to send us a written account, stating specific instances with as much detail as possible about the incident concerning our dealer. This will enable us to improve the OSSA MOTOR customer service and services in general.

Thank you and we hope you enjoy your new motorcycle.

www.ossamotor.es

Ossa Motor
Carretera antiga d'Amer, nau 12
17007 Girona, Spain

tel 0034 972 107 107
fax 0034 972 117 899